



McMillan
FLOW PRODUCTS

IRIDIUM

SERIES FLOW CONTROL

6010-01-C1 Configuration
Liquid Applications



INTELLIGENT • MODULAR • FLEXIBLE



WHAT IS IRIDIUM FLOW CONTROL?

Iridium is a platform for configurable flow control. Its modular design allows for a single device to adapt to a variety of flow conditions and applications.

6010-01-C1 Configuration

Though the Iridium is modular and can be built in many configurations, there are several common setups offered as “factory” configurations. This brochure discusses the 6010-01-C1 Configuration for Liquids, which features a PTFE microturbine flow sensing module (A601) and a PTFE proportional diaphragm flow control module (B601). This configuration can be set up to control liquid flow ranges as low as 7-50 mL/minute and as high as 1.0-10.0 L/minute. Other configurations can be custom built as desired.

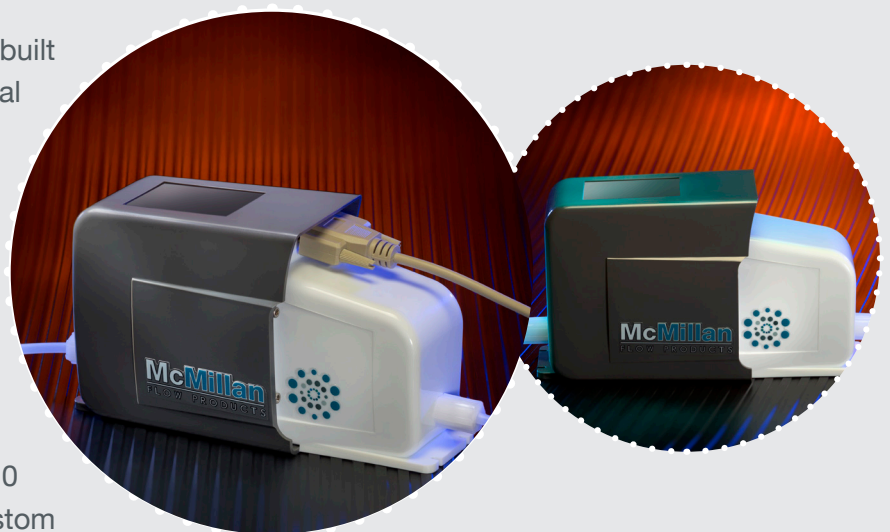

How Does a Flow Controller Function?

Flow controllers use an integrated flow rate sensor and control valve to regulate flow rate regardless of inlet pressure fluctuations. A flow control setpoint is provided a) by a user via the touchscreen, or b) remotely via an electronic signal. The controller then adjusts the integrated valve as needed to maintain the desired flow rate.

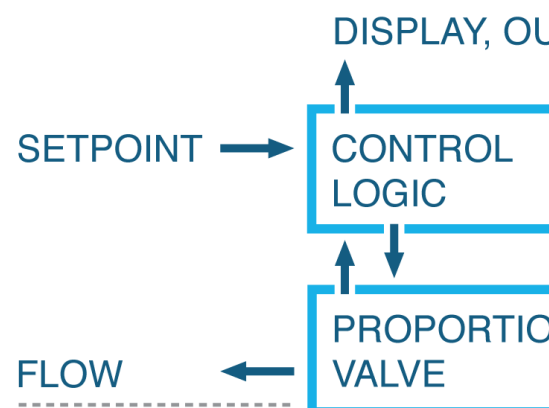

Multiple I/O Options

USB and RS485 interfaces are standard. Analog (mA or VDC) and relay outputs available as options.

Liquid Flow Ranges

Flow ranges as low as 7-50 mL/minute and as high as 1.0-10.0 L/minute are available.

PTFE Flow Path

Wetted materials of only PTFE, sapphire and Viton® (Kalrez® optional) ensure compatibility.



INTEGRATED TOUCHSCREEN



Using the integrated 3.2" color touchscreen, users can display flow rate, totalized flow, alarm states, and more. Most configuration settings can be modified via the screen, including engineering units, set points, and calibration curves. Settings may be accessed by USB if the touchscreen is not accessible.

PELTON MICROTURBINE



For repeatable liquid flow measurement, the A601 flow module uses a miniature PTFE microturbine wheel suspended on a sapphire shaft. An infrared beam detects the rotation speed. The zero-friction design provides fast response and no particle generation.

FAST CONTROL LOGIC



By utilizing advanced microprocessors and specially designed software, the Iridium flow controller is able to react to both small and large changes in supply pressure or setpoint and adjust the flow rate almost instantly. Smart logic minimizes overshoots and erratic valve actions.

EXPANSION SLOTS



As part of its modular construction, the Iridium platform has two open slots for expansion cards. Features include analog I/O, wireless communication, error outputs, and can also be customized as needed. Two cards can be used simultaneously. Just like the flow modules, expansion cards can be installed by the user.

OUTPUTS

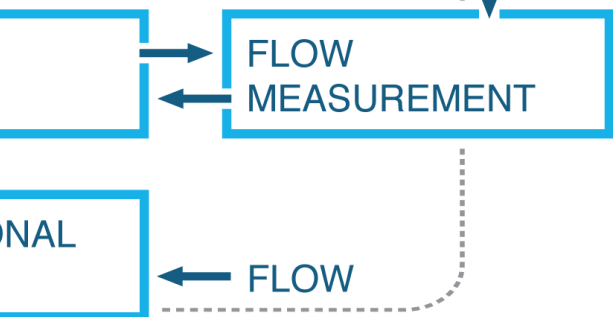

Sample Applications

- » On-demand chemical dilution and blending
- » Sample flow rate regulation
- » Consumable usage monitoring and regulation

MODULAR

FIELD-SERVICEABLE

If you need to swap a module or change a fitting type, the change can be made in the field with no need to return to the factory.

VARIOUS CONFIGURATIONS

Because changes can be made so easily, users can use one Iridium for multiple ranges and configurations.

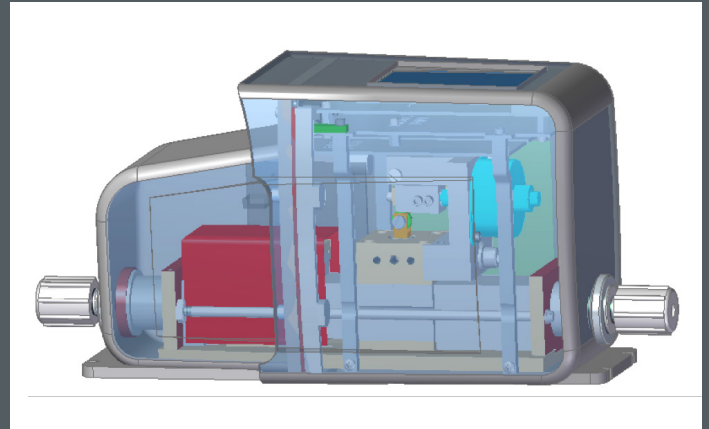

CHANGING MODULES

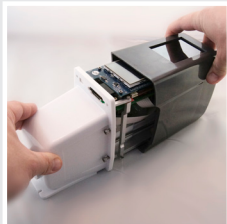

Step 1:
Remove
Case

The two halves of the case can be separated by removing only six bolts and two lock rings. The case will then slide off.

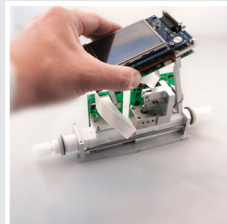

Step 2:
Remove Main
Electronics

For easier access to the modules, the display and main electronics can be removed with three bolts. Unplug cables as needed.

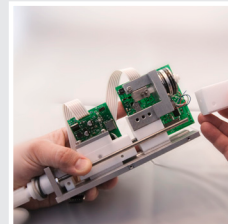

Step 3:
Remove
Module(s)

The module track is held together using two special bolts. Once those are removed, each fluid module is free to slide out.

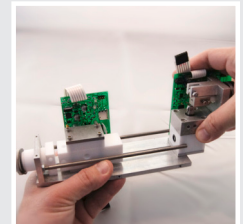

Step 4:
Install &
Reassemble

The new modules can easily be installed by sliding on the track. The previous steps are then reversed to reassemble.

AVAILABLE OPTIONS AND UPGRADES

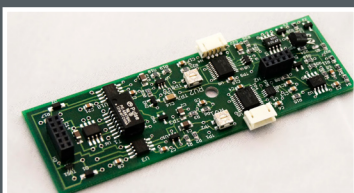

ANALOG I/O MODULE: Enables the Iridium to receive and transmit analog signals such as 4-20 mA, 0-20 mA, 0-10 VDC, etc. All signals are fully isolated.

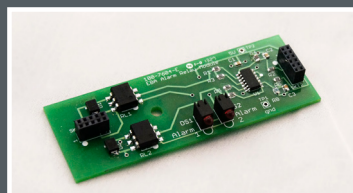

ALARM OUTPUT MODULE: Enables the alarms that are built-in to the Iridium to be transmitted externally via relay contacts.



WATER PROOF MODULE: Provides splash protection (up to IP65) for the Iridium by encapsulating all electrical connections.

FLEXIBLE



GRAPHICAL INTERFACE

Through the integrated 3.2" touchscreen, the user can program setpoints, display current status, and adjust configuration while the unit continues to control flow rate and provide output. Where required, the touchscreen can become a digital keypad for simple numeric value entry.



SOFTWARE UPDATE

The Iridium platform can easily be upgraded through downloadable firmware updates via the standard USB interface. In addition, the factory can provide customized software packages with unique configurations to match specific applications or process conditions.



I/O OPTIONS

RS485 serial interface and Universal Serial Bus (USB) interfaces are standard. The Iridium also has two internal expandable card slots. A popular option is the Analog I/O module, which provides isolated mA or VDC I/O for setpoint (input) and current flow rate (output) communication.



MODULAR DESIGN

The Iridium platform supports field-replacement of internal modules as needed, allowing the users to swap flow ranges, valve types, I/O modules, and more as application conditions change. These swaps take only minutes and provide virtually limitless configurations.



FLOW RANGES

With the Iridium 6010-01-C1 configuration, flow ranges for liquids are available as low as 7-50 mL/minute all the way up to 1.0-10.0 L/minute. Most ranges feature a 1:10 turn-down (or better) and repeatable, accurate control can be expected across the entire specified range.



FITTING CHOICES

The modular design of the Iridium also allows for inlet and outlet fitting sizes and types to be changed as needed. FNPT, compression, flare, and other fitting types are available in sizes as small as 1/8" or as large as 1/2". Metric sizes may also be available upon request.



KALREZ® SEAL KIT: Replace the standard Viton® seals with Kalrez® for enhanced chemical compatibility.



TILT STAND: Bracket that supports the Iridium on an angle for easier use of the display in a laboratory environment.

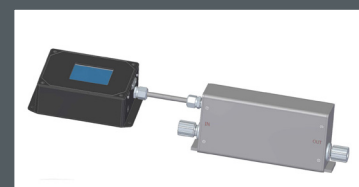

INTEGRATED MODEL: Contact factory for details on the Iridium Industrial, which separates the display from the fluid components.

DETAILED INFORMATION

Iridium 6010-01-C1 Configuration A601 Flow Sensing Module | B601 Control Valve Module

Specifications

Accuracy (including linearity, best fit straight line)	±1.0% typical from factory, full scale ±0.5% typical with user calibration, full scale
Repeatability	±0.5% or better typical, ±0.2% best conditions
Maximum Pressure Rating	80 psig (5.4 bar) maximum working 100 psig (6.8 bar) overpressure
Temperature Rating (Fluid)	5 to 40 °C Higher temperature modules available
Environmental Rating	Operating Temperature : 5 to 50 °C Storage Temperature: 0 to 70 °C Relative Humidity: 20 to 85%
Wetted Materials	PTFE Sapphire
Seal Materials	Viton® standard Kalrez® option available [EKZ]
Compatible Fluids	Most low viscosity fluids Minimum of entrained air - at low flow ranges
Valve Type	PTFE diaphragm, cam-driven
Standard I/O Interfaces	USB 2.0 RS485
Optional I/O Interfaces	Analog I/O Card [EAA] VDC Input (0-10 VDC or 0-5VDC, user selectable) 200Kohm or higher typical input resistance Isolated from power VDC Output (0-10 VDC or 0-5VDC, user selectable) 5Kohm or higher acceptable load Isolated from power mA Input (0-20 mA or 4-20 mA, user selectable) Isolated from power mA Output (0-20 mA or 4-20 mA, user selectable) Passive, 500 ohm or lower loop resistance Isolated from power
Optional Relay Interfaces	Alarm Output Card [EBA] 2 relays User configurable menu selections Rating: maximum 0.4 A, 30 VDC
Zero Drift	None
Warm-Up/Boot Time	<10 seconds typical
Power Requirement	Recommended Voltage: 24 VDC (16-25VDC, user selectable) 2.5 watts typical power consumption Reverse polarity and overvoltage protected
Electrical Connections	15-pin Male D-Sub Micro-USB
Response Time	Adjustable, typically <2 seconds to final value
Display [Standard]	3.2" (86 mm) TFT LCD color display Resistive touchscreen panel
Differential Pressure Typical Configuration*	20 psid (1.36 bar) to reach 100% rated flow Minimum 5 psid (0.34 bar) to reach 50% rated flow Not to exceed 50 psid (3.4 bar) *Other differential pressure configurations available

Ordering Information

Form Part Number:

6010-01-C1-(Flow Range)-(Fittings)-(EAA)-(EBA)-(EKZ)-(Zxxxx)
Items in *italics* are optional

Example: 6010-01-C1-5-F6-EKZ

Model	6010
Version	01
Configuration	C1
Flow Range (mL/minute of H2O)	
	7-50 2
	10-100 3
	20-200 4
	50-500 5
	100-1,000 6
	200-2,000 7
	500-5,000 8
	1,000-10,000 9
Fittings (inlet/outlet)	
	1/4" Male Flaretek® F4
	3/8" Male Flaretek® F6
	1/2" Male Flaretek® F7
	1/8" FNPT N2
	1/4" FNPT N4
	3/8" FNPT N6
Analog I/O Expansion Card (optional)	EAA
Relay Output Card (optional)	EBA
Kalrez® Seals (instead of standard Viton®)	EKZ
Custom Configuration	Zxxxx (xxxx is a numeric value assigned by the factory)

Compatible Range/Fitting Chart

Flow Range	F4	F6	F7	N2	N4	N6
2	✓			✓		
3	✓			✓		
4	✓	✓		✓		
5	✓	✓		✓	✓	
6	✓	✓		✓	✓	
7		✓		✓	✓	
8		✓	✓	✓	✓	✓
9		✓	✓		✓	✓

✓ = Available

DIMENSIONS

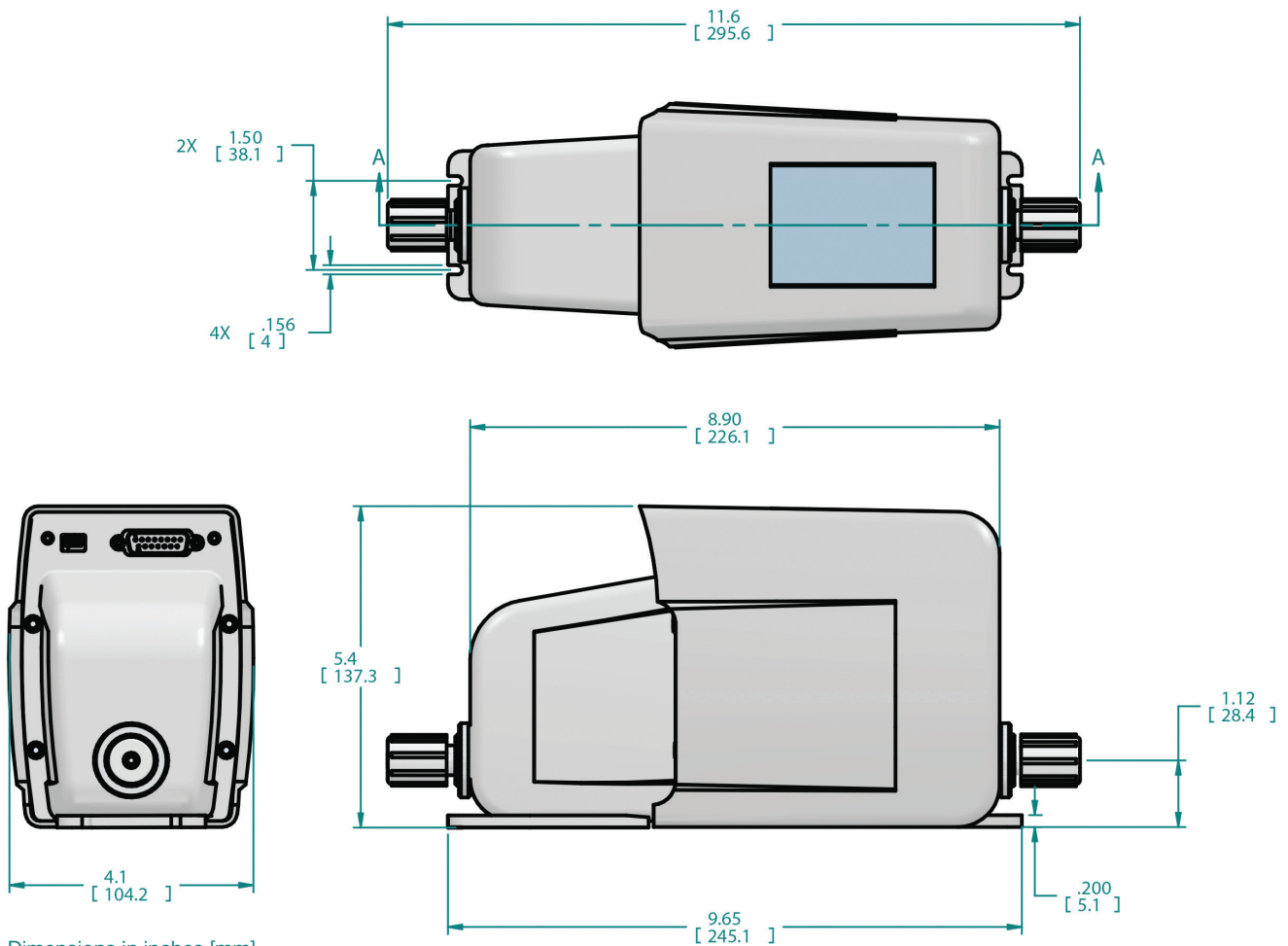

Other Products by McMillan



MODEL 101: Constructed from PPS/Ryton®, the Model 101 FLO-SENSOR incorporates a linear analog output and is a low cost, highly accurate plastic flow meter for liquid flow rates as low as 13 mL/minute.



MODEL 104: For applications that require a metal body, the Model 104 FLO-SENSOR is the stainless steel version of the Model 101. Rated up to 500 psig and available with a 4-20 mA output (Model 107).



MODEL U707: If chemical compatibility is important, the Model U707 FLO-SENSOR features only PTFE, sapphire, and Kalrez® wetted parts. It can measure as low as 7-50 mL/minute.



MODEL U709: Designed for chemical dispense applications, the Model U709 FLO-MONITOR will monitor very short dispenses (<500 milliseconds). It features a PTFE flow path for compatibility.



MODEL 109: For very low flow rates as low as 0.05 mL/minute (50 microliters/minute), the Model 109 FLO-SENSOR will report realtime flow rate via a linearized, analog signal.



MODEL S-114: For laboratory or R&D applications, the S-114 FLO-METER incorporates an LCD screen to display realtime flow rate in mL or L/minute. An analog output also comes standard.

ABOUT MCMILLAN

McMillan is a world leader in providing flow measurement and control products to engineers and researchers from various industries. By developing technologies that offer reasonable cost, precise measurement, and compact size, McMillan products solve many challenges encountered in instrumentation and equipment design. As a family-owned small business, friendliness, helpfulness, and willingness are instrumental to continued success.



PO Box 1340
Georgetown, Texas 78627
United States of America
Tel: +1 512 863 0231
Fax: +1 512 863 0671
Email: sales@mcmflow.com

www.iridiumflow.com